



FilterFab **MODEL MFU-3110P** PORTABLE FILTRATION SYSTEM

Eliminating Varnish, Sludge, Water, and Particulate Contamination in Lubricating Oils and Fluid Power Systems

Contact us today for pricing
931.526.3146
Filters@Filter-Fab.com

600 GPH

APPLICATIONS

Hydraulic Oil • Compressor Oil • Quench Oil
EDM Oil • Lubricating Oil • Insulating Oil
Turbine Oil • Gear Oil • Water Glycol Fluids
Water Based Coolants

SPECIFICATIONS

- 1 HP TEFC Heavy Duty Motor with Thermal Overload Protection.
- 10 GPM Mechanically Sealed Positive Displacement Gear Pump with Internal Relief Valve.
- One (1) Polyurethane Powder Baked MFU-3000F Element Housing.
- Wired 110 volt, 1 Phase with all electrical components mounted in a NEMA 4 enclosure.
- Automatic High/Low Pressure Shut Down System for unattended operation.
- 0-100 PSI Glycerin Filled Gauge for monitoring system pressure.
- Plumbed with 3/4" Brass fittings and 2000 PSI High Pressure Steel Braided Hydraulic Hose with crimped hose ends.
- Two (2) 15 ft.-3/4" inlet and outlet hydraulic hoses with hose ends.
- Fifteen (15) feet of Heavy Duty 12/3 Power Cable.
- Manufactured with 3-way ball valve for Fluid Transfer System and to allow for adding makeup oil.
- Suction-Wye Strainer to protect pump from large debris.
- Heavy duty 12" pneumatic tires.
- Filtration Capacity of 10 GPM with Fluid Transfer Setup.



REDUCE MAINTENANCE EXTEND OIL AND EQUIPMENT LIFE

REDUCING YOUR COSTS TODAY TO INCREASE YOUR PROFITS TOMORROW

MODEL MFU-3110P

**Portable Oil Filtration System for
Lubricating and Fluid Power Applications**

600 GPH

BACK

SIDE

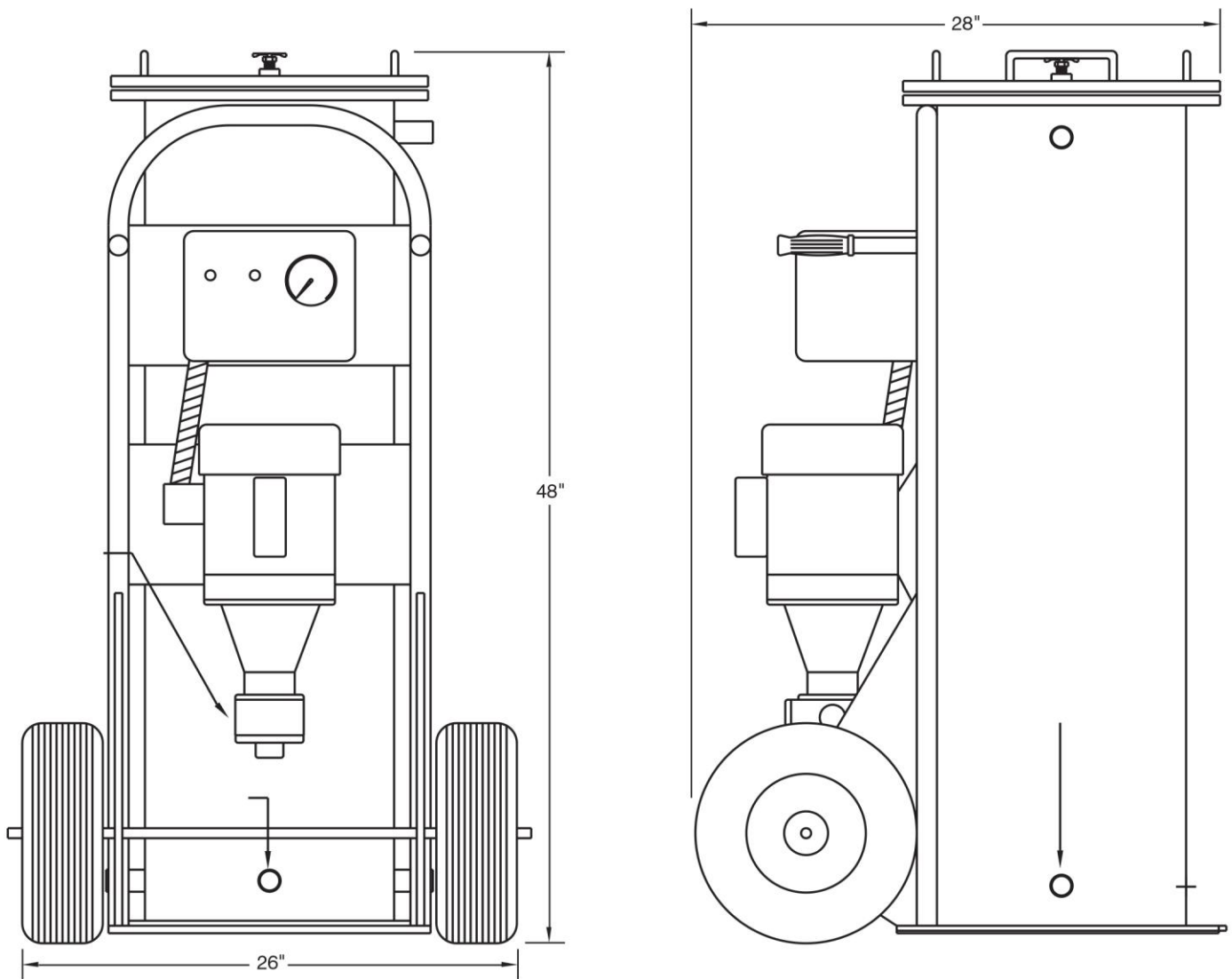

Filter-Fab • 2188 Fisk Road • Cookeville, TN 38506 • 931.526.3146 • www.filter-fab.com

Product status and specifications are subject to change.

DISCLAIMER: Filter-Fab reserves the right to the product(s) and or information contained herein without notice. No liability is assumed as a result of there use or application. No rights under an patent accompany the sale of any such product(s) or information.