



FilterFab MODEL MFU-2130P

PORTABLE FILTRATION SYSTEM

High Performance Filtration for Today's Industry

1800 GPH

Contact us today for pricing
931.526.3146
Filters@Filter-Fab.com



APPLICATIONS

Hydraulic Oil • Compressor Oil • Quench Oil
EDM Oil • Lubricating Oil • Insulating Oil
Turbine Oil

SPECIFICATIONS

- Heavy duty 2 HP TEFC 230 volt single phase Baldor motor with manual thermal overload protection.
- 30 GPM positive displacement mechanical seal gear pump with internal relief valve.
- One (1) polyurethane powder baked high flow element housing.
- Wired 230 Volt 1 phase with all electric components mounted in a NEMA 4 enclosure.
- **Manufactured with automatic high pressure shutdown system for unattended operation.**
- **Motor starter with on/off toggle switch**
- Plumbed with all brass and black iron fittings
- 1½" inlet and outlet ports with cam loc fittings.
- Fifteen (15) feet of heavy duty 12/3 power cord.
- **Manufactured with 3-way ball valves for fluid transfer System.**
- Suction-wye strainer to protect pump from large debris.
- 0-100 PSI glycerin filled gauge for monitoring system Pressure.
- Inline brass re-settable flow totalizer.
- Heavy duty 12" pneumatic tires.
- Filtration capacity of 27 GPM and fluid transfer capacity of 30 GPM.

***Available in 110 VAC**



REDUCING YOUR COSTS TODAY TO INCREASE YOUR PROFITS TOMORROW

MODEL MFU-2130P

High-Flow Water and Particulate Oil Filtration System

1800 GPH

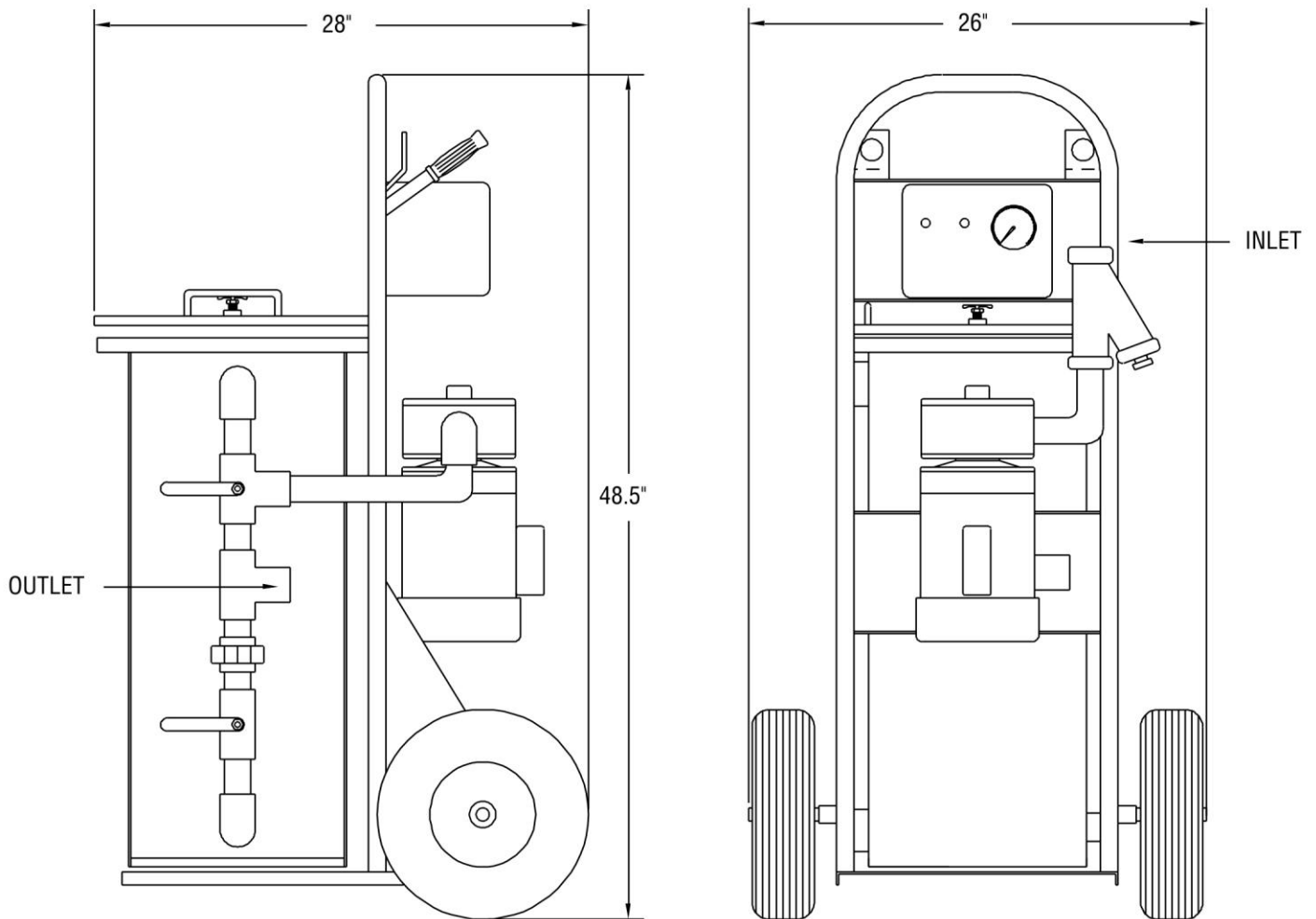

Unit Weight: 220 lbs. Shipping Weight: 300 lbs.
(weights are approximate)

Filter-Fab • 2188 Fisk Road • Cookeville, TN 38506 • 931.526.3146 • www.filter-fab.com

Product status and specifications are subject to change.

DISCLAIMER: Filter-Fab reserves the right to the product(s) and or information contained herein without notice. No liability is assumed as a result of there use or application. No rights under an patent accompany the sale of any such product(s) or information.